

Specification Approval Sheet

Customer Name: _____

Customer Model: _____

Product Model: NUE11SJJ68421133X6A

Prepared by	Checked by	Approved by
Zhou Xinping	Ou Jianping	Wu Fuquan

Customer Approved (Stamp)	Test by	Checked by	Approved by

Revision History

Revision	Description	Date	Approval
1.00	New released	2016-06-22	

Contents

1. Scope
 2. Product basic information
 3. Battery Outline Drawing
 4. Electrical characteristics
 5. Condition adapting characteristics
 6. Cell safety performance
 7. Battery safety performance
 8. Others
 9. Testing requirements
 10. Electrical Characteristics
 11. Cell
 12. Electric Protect Features
 13. Schematic circuit diagram
 14. PCB Parts List BOM
 15. PCB Layout PCB
 16. Package
 17. Battery Precautions and Safety Instructions
- Customer Inquiry

1. Scope

The specification shall be applied to Lithium-ion Polymer (LIP) rechargeable battery pack which is manufactured by **NuEnergy Storage Technologies**.

Reference standard

GB/T 18287-2013IEC/EN61960UL1642

2. Product basic information

Items	Parameter	
Battery model	NUE11SJJ68421133X6A	
Design scheme	DW01A + 8205A	
Nominal voltage	3.7V	
Minimum capacity	3600mAh (0.2C discharge)	
Typical capacity	3650mAh (0.2C discharge)	
Charging voltage	4.2V	
Discharging cut-off voltage	3.0V	
Standard charging	0.2C /4.2V	
Max charging	1.0C /4.2V	
Standard discharging	0.2C/3.0V	
Max discharging	1.0C/3.0V	
Weight	Approx. 27g	
Shipment voltage	≥3.85V	
Battery pack impedance	≤160mΩ	
Operating temperature	Charging: 0°C ~ 45°C	
	Discharging: -20°C ~60°C	
Storage (At 50% SOC and specified temp, recoverable capacity in % vs time.)	-10°C~25°C	(12 months, ≥85%)
	-10°C ~45°C	(6 months, ≥85%)
	-10°C~55°C	(1 month, ≥90%)
	20±5°C is the recommended storage temperature	
Visual Inspection	There should not be any remarkable scratches, cracks, bolts, cauterization, deformations, swelling, leakage and so on the surface of the cell.	

3. Battery Outline Drawing

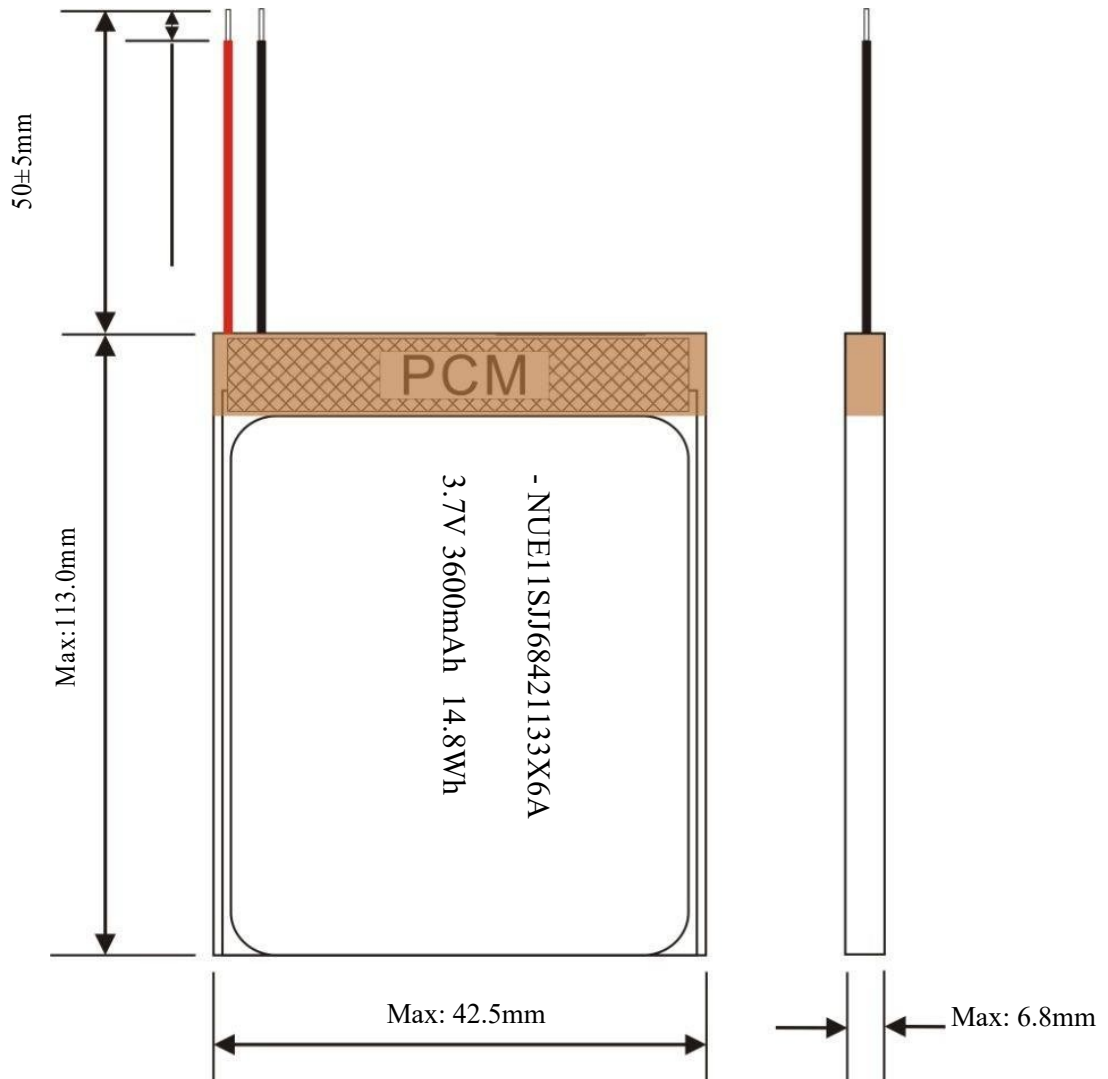

BOM (Bill of materials)

NO.	Material Name	Specification	Qty	Remark
1	Cell	6842113/3600mAh/3.7V	1	RoHS
2	Protection board	PCB3036	1	RoHS
3	Wire	Red Wire UL1007#24	1	RoHS
		Black Wire UL1007#24	1	RoHS
4			1	RoHS

4. Electrical characteristics

No.	Items	Test Method	Criteria
1	Standard Charge	Charging the cell initially with constant current at 0.2C and then with constant voltage at 4.2V till charge current declines to 0.02C.	N/A
2	Minimal Capacity	The capacity means the discharge capacity of the cell, which is measured with discharge current of 0.2C with 3.0V cut-off voltage after the standard charge.	≥3600mAh
3	Charge/Discharge Cycle	The capacity on 0.2C discharge shall be measured after 300 cycles of 0.2C charge and discharge at 23±2°C.	Capacity≥80%
4	Retention Capability	After full charging, storing the battery 28 days with 20 ± 5°C condition, and then staying 1 hours with discharge current of 0.2C till 3.0V cut-off voltage.	Capacity≥85%

※ Typical capacity

The capacity means the average discharge capacity of the cell, which is measured with discharge current of 0.2C with 3.0V cut-off voltage after the standard charge at 23±2°C environment temperature, unit: mAh

5. Condition adapting characteristics

No.	Items	Test Method	Criteria
1	Constant temperature and Humidity	After standard charging, put cell into the box that the temperature is $40\pm 2^{\circ}\text{C}$ and the humidity ranges between 90-95% for 48 hours, then put it at $23\pm 2^{\circ}\text{C}$ for 2 hours, then discharge with current of 0.2C to the cut-off voltage.	No distortion, no rust, no leakage, no venting, no rupture, no fire, no explosion, the discharge time is not less than 3hrs.
2	High Temperature Performance Test	After full charging, put the cell into box with high temperature of $55^{\circ}\text{C}\pm 2^{\circ}\text{C}$ for 2h, then discharge with current of 1.0C to the cut-off voltage.	No distortion, no rupture, no fire, no smoke or leakage Discharge time ≥ 51 min
3	Low Temperature Performance Test	After full charging, put the cell into box with low temperature of $-10\pm 2^{\circ}\text{C}$ for 16~24h, then discharge with current of 0.2C to the cut-off voltage.	No distortion, no rupture, no fire, smoke or leakage Discharge time ≥ 3 h

6. Cell safety performance

No.	Items	Test Method	Criteria
1	Cell Overcharge	After discharge to limit voltage, charged at constant current of 3C and constant voltage of 4.6V, while voltage reaches to the max, if charging continued over 7 hours or temperature is 20% less than the top, close the test.	No explosion and no fire.
2	External Short-circuit Test	Cell terminals are short-circuited to discharged state less than 0.1V or longer time with a resistance of 50mΩ or less. Tests are to be conducted at room temperature.	No explosion and no fire.
3	Over-Discharge Test	Cell is discharged at a current of 1C rate for 2.5 hours. (If current stops by safety or passive circuit on the battery, test is finished.).	No explosion and no fire.
4	Crush Test	Crush between two flat plates. Applied force is about 13kN.	No explosion and no fire.
5	Impact Test	Impact between bar (15.8mm diameter) and 9.1Kg falling material (at a height of 6.1cm). Bar is laid across the center of the test sample.	No explosion and no fire.

PRODUCT SPECIFICATION

6	Drop	After standard charging, the cell is to be dropped from a height of 1.2meter onto a thickness of 20mm board, dropped once in the positive and negative directions of three mutually perpendicular X, Y, Z axes.	No leakage, no smoke, no fire, no explosion.
7	Vibration Test	Fixed the fully charged cell to vibration table and subjected to vibration cycling that the frequency is to be varied at the rate of 1Hz per minute between 10Hz and 55Hz, the excursion of the vibration is 0.8mm. The cell shall be vibrated for 90 ~100 minutes per axis of XYZ axes.	No explosion, no fire, no leakage.
8	Heating	After standard charging, put cell in the baking oven and start, the temperature of the oven is to be raised at a rate of $5\pm 2^{\circ}\text{C}$ per minute to a temperature of $130\pm 2^{\circ}\text{C}$, remain for 30minutes at that temperature.	No explosion and no fire.

7. Battery safety performance

1	Overcharge protection	After battery charge finished, then charge the battery for 8 hours with a power which can provide 2 times more than nominal voltage and 2C ₅ A current.	No fire, no explosion. The electrical properties of normal.
2	Over discharge protection	After the battery is fully charged, discharge at 20±5°C conditions with 0.2C ₅ A until the battery voltage drops to the over discharge voltage, then discharge with a 30Ω resistor for 24 hours.	No fire, no explosion. The electrical properties of normal.
3	Short protection	After standard charging, connect the positive and negative terminals of the cell with copper wire having a maximum resistance load of 0.1 Ω at room temperature, the test is discontinued when the surface temperature lower than 10°C.	The battery shall no rupture, smoke, catch fire, or leakage. Battery Voltage ≥3.6V

8. Others

Any matters that this specification doesn't cover should be conferred between the customer and NuE.

9. Testing requirements

9.1 Battery test environment

Temperature: 23±2°C

Relative humidity: 60± 20% RH

Atmospheric pressure: 86106 KPa

9.2 Measuring instrumentation requirements

Voltage instrumentation requirements: Measuring the voltage meter accuracy no less than 0.5 magnitude

Current instrumentation requirements: Measuring the current meter accuracy no less than 0.5 magnitude

Time instrumentation requirements: Measuring the time meter accuracy no less than 0.1%

Temperature instrumentation requirements: Measuring the temperature meter accuracy no less than 0.5°C

Impedance instrumentation requirements: Measuring impedance should be by sinusoidal alternating (1 KHZ) test

10. Electrical Characteristics

10.1 Battery charge/discharge

10.1.1 Full charged definition

With charging voltage 4.2V, current 0.2C continued to charge the battery pack, when charging current drops to 0.02C charging is terminated, shall be full charged.

10.1.2 Full discharged definition

Standard discharge current 0.2 C for continuous discharge, when the voltage drops to discharge cut-off voltage 3.0V discharge is terminated, shall be full discharged.

11. Cell

11.1 Performance parameters

No.	Specification	Project	Remarks	
1	Cell minimum capacity	3600mAh	0.2C discharge	
2	Initial impedance	≤60mΩ	1kHz AC Impedance	
3	Nominal voltage	3.7V	/	
4	Dimensions	T	6.8	Thickness
		W	42.5mm Max	Width
		L	110.0mm Max	Cell length not including Tab sealant
		A	21.0±2.0mm	Distance of tab center
		B	4.0±0.2mm	Tab width

11.2 Cell outline drawing

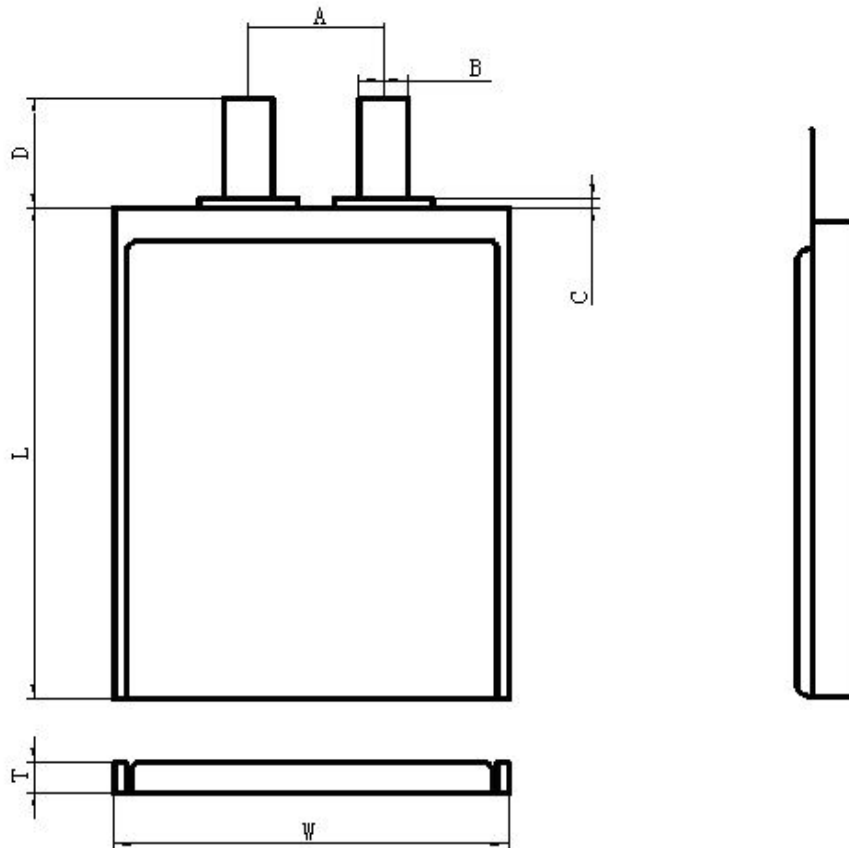

12. Electric Protect Features

Item	Symbol	Content	Criterion
Over charge Protection	V_{DET1}	Over charge detection voltage	$4.30V \pm 0.05V$
	tV_{DET1}	Over charge detection delay time	200msMAX
	V_{REL1}	Over charge release voltage	$4.10V \pm 0.1V$
Over discharge protection	V_{DET2}	Over discharge detection voltage	$2.40V \pm 0.1V$
	tV_{DET2}	Over discharge detection delay time	100msMAX
	V_{REL2}	Over discharge release voltage	$3.0 \pm 0.10V$
Over current protection	V_{DET3}	Over current detection voltage	$150mV \pm 30mV$
	I_{DP}	Over current detection current	MIN2.5A MAX5.0A
	tV_{DET3}	Detection delay time	20msMAX
		Release condition	Cut load
Short protection		Detection condition	Exterior short circuit
	T_{SHORT}	Detection delay time	0.5msMAX
		Release condition	Cut short circuit
Interior resistance	R_{DS}	Main loop electrify resistance	B- P- $R_{DS} \leq 70m\Omega$
Current consumption	I_{DD}	Current consumes in normal operation	MIN0.3 μ A MAX10.0 μ A
0V Prohibition /allowance		allowance	

13. Schematic circuit diagram

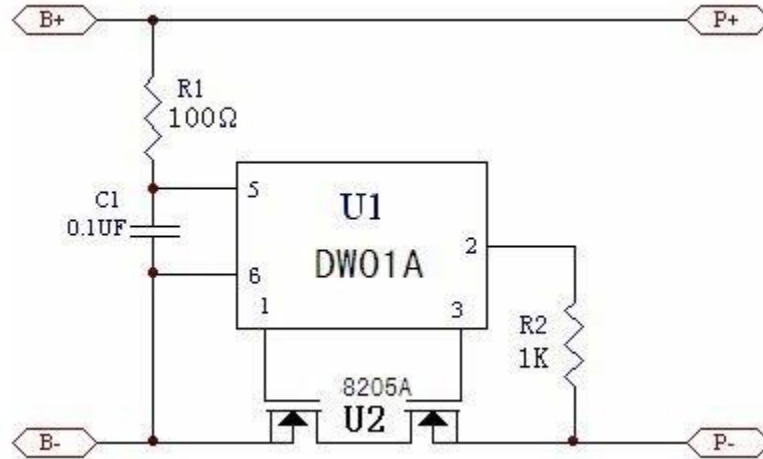

14. PCB Parts List BOM

Item	Part Name	Description	QTY	Footprint	Supplier	Remark
1	U1	DW01A	1pcs	SOT-23-6		
2	U2	8205A	1pcs	TSS0P-8		
3	C1	SMD 100Ω±5%	1pcs	0603	Any approved vendor	
4	R1	SMD 1KΩ±5%	1pcs	0603	Any approved vendor SKYWELL, YAGEO, or	
5	R2	SMD 0.1μF±20%	1pcs	0603	Any approved vendor SKYWELL, YAGEO, or	
6	PCB	PCB3036	30mm*3.6mm*0.6mm±0.15mm		Any approved vendor	

15. PCB Layout PCB

Top Layer

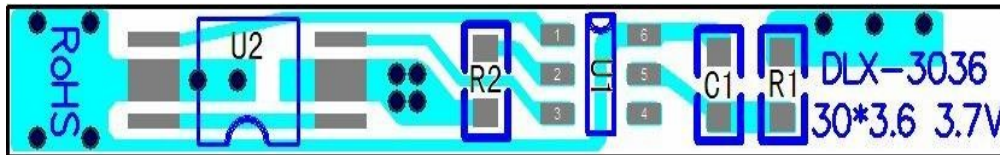

Bottom Layer

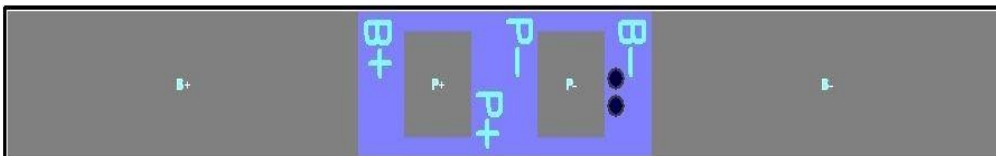

16. Package

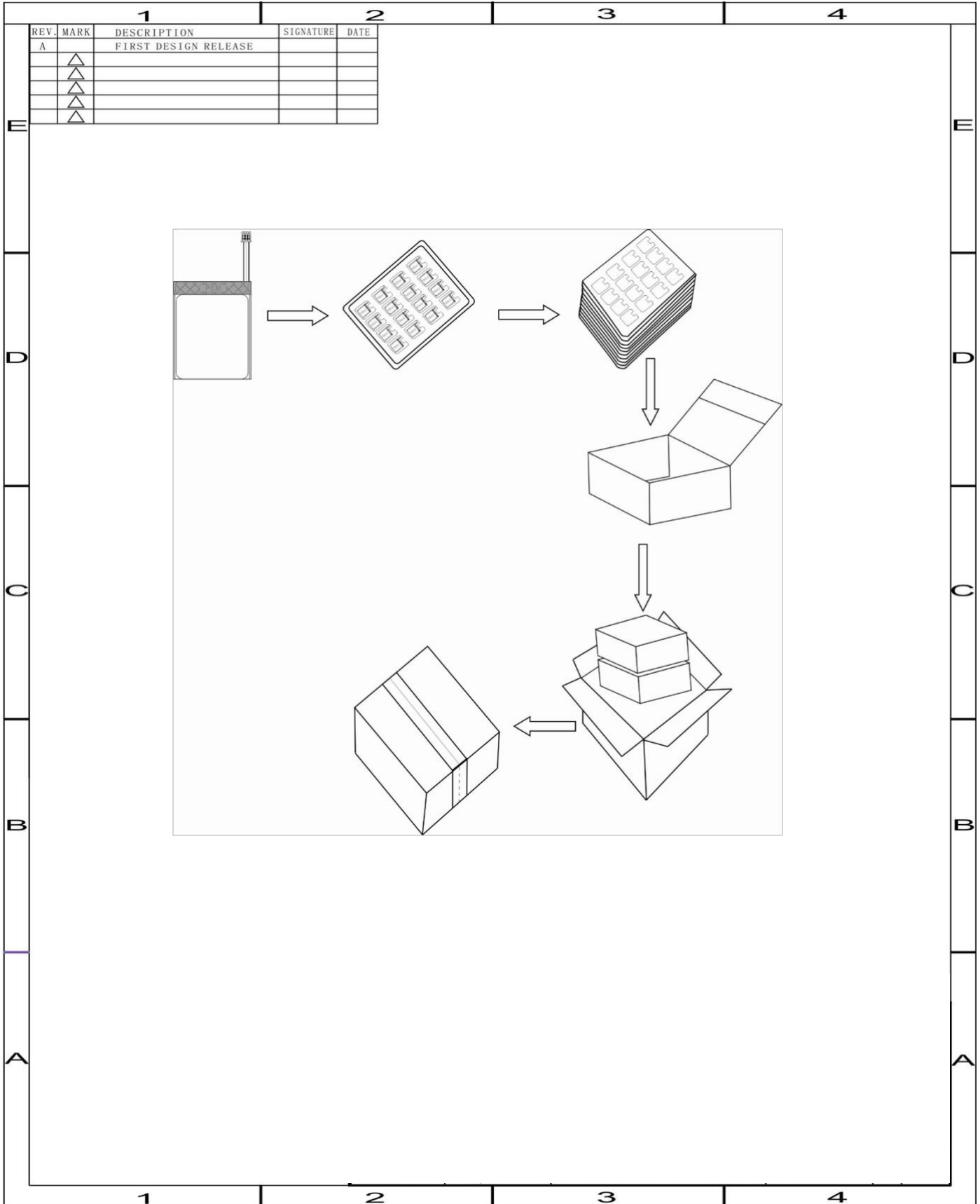

17. Battery Precautions and Safety Instructions

Please be sure to take to comply with the specifications and the following precautions to use with batteries, did not follow the specifications for the operation caused any accidents, NuEnergy Storage Technologies will not accept any responsibility.

- Guarantee to keep the battery in good repair in 12 months from the shipment.
- Please use 0.5C current to charge up 60% capacity after the battery placed 3 months.
- Before Use the battery, carefully read the instruction manual and battery labels on the surface.
- Need to use the original battery charger and should be placed in a dry ventilated place.
- Such as long-term when not in use, the battery charger to charge state half full, remove the battery from the device and separated, to avoid metal contact with the battery, causing short-circuit or damage to the phenomenon.
- In use or during storage, battery found there has been high fever, leakage, odor, distortion and other anomalies, please stop using it immediately and stay away from the battery.
- Do not short-circuit the battery positive and negative, and careful not to allow the battery to moisture, to avoid danger.
- When using, keep away from heat and high-pressure place, and do not beat or hit the battery.
- Battery at end of life should be immediately removed from the equipment, please properly handle security of spent batteries, do not put into fire or water.

Customer Inquiry

1. If clientele ratify specification and showpiece, please sign back specification to NuE in 1 week,
2. The customer is requested to write down your information and contact NuE in advance, if and when the customer needs applications or operating conditions other than those described in this document. NuE could design and build such products according to your special request.

	Special Request	Criteria
1		
2		
3		
4		
5		
6		

Company Name:**Signature:****Date:**